

NESTiG

Castle Canopy Kids Bed



Please read all instructions before assembly
and use of product!

Lisez toutes les instructions avant
d'assembler et d'utiliser le produit!

Welcome to the Nestig World!

Our Warranty

Our twin beds come with a limited 2 year warranty! We do our best to ensure everything arrives in perfect shape but if anything arrives damaged, missing, or defective, our Customer Experience team is here to help.—just email us at hello@nestig.com!

For more information on our warranty, visit:

<https://www.nestig.com/pages/warranty-policy>

Bed Care & Tips

- To clean your bed, use a soft cloth with a non-toxic cleaner and wipe dry immediately.
- To avoid scratches or other damages, do not use abrasive chemicals or materials.
- Any dramatic changes such as extreme heat, cold, dampness or dryness may cause shrinkage or swelling of the wood.
- Placing the bed in direct sunlight may affect the color of the materials over time.
- Tighten all screws periodically.
- Do not drag the bed - when moving, always use two people to lift it.

Bienvenue dans le monde de Nestig!

Notre garantie

Nos lits jumeaux sont assortis d'une garantie limitée de 2 ans! Nous faisons de notre mieux pour que tout arrive en parfaite forme mais si quelque chose arrive endommagé, manquant ou défectueux, notre équipe Expérience Client est heureuse de vous aider. Envoyez-nous un e-mail à hello@nestig.com!

Pour plus d'informations sur notre garantie, visitez:

<https://www.nestig.com/pages/warranty-policy>

Entretien et conseils pour les lits

- Pour nettoyer votre lit, utilisez un chiffon doux avec un nettoyant non toxique et essuyez immédiatement.
- Pour éviter les rayures ou autres dommages, n'utilisez pas de produits chimiques ou de matériaux abrasifs.
- Tout changement dramatique tel qu'une chaleur extrême, le froid, l'humidité ou la sécheresse peut provoquer le rétrécissement ou le gonflement du bois.
- Placer le lit en plein soleil peut affecter la couleur des matériaux au fil du temps.
- Serrez toutes les vis périodiquement.
- Ne pas le traîner ni le pousser au sol - si vous déplacez le lit, deux personnes doivent le soulever.



WARNING:

The maximum weight supported on the bed is 242.5 lbs(110 kg). No weight should be applied to the upper bars. Adult assembly required. Check the product periodically and tighten any loose hardware.



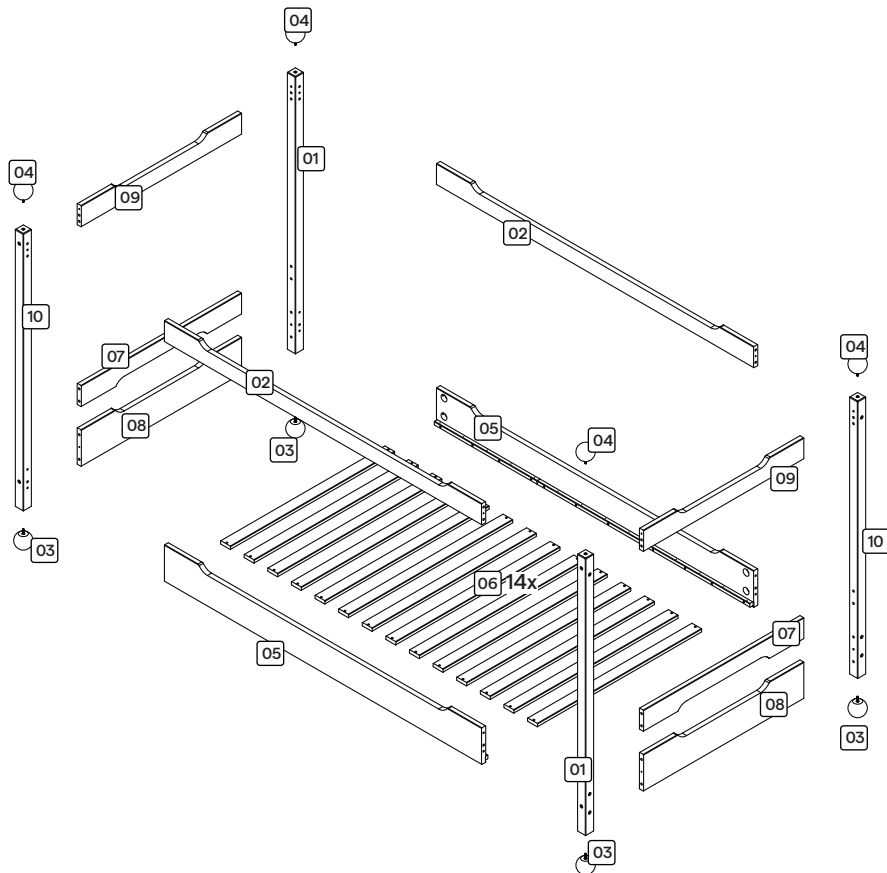

MISE EN GARDE

Le poids maximum supporté sur le lit est de 242,5 lb (110 kg). Aucun poids ne doit être appliqué sur les barres supérieures. Assemblage par un adulte requis. Vérifiez périodiquement le produit et resserrez tout matériel desserré.

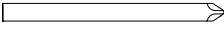

Item / Pièce	Description / Description	Quantity/Quantité
01	Post "A" / Poste "A"	02
02	Upper bar / Barre supérieure	02
03	Feet / Pieds	04
04	Wooden ball knob / Bouton boule en bois	04
05	Bar / Barre	02
06	Bed slats / lattes de lit	14
07	Headboard center crossbar / Traverse centrale de tête de lit	02
08	Headboard bottom crossbar / Traverse inférieure de tête de lit	02
09	Headboard top crossbar / Traverse de la tête de lit	02
10	Post "B" / Poste "B"	02

Not Included / Non Inclus	
	Hammer / Marteau
	Philips head screwdriver Tournevis à tête Philips
	Electric screwdriver Tournevis électrique



2 people / personnes

Hardware list / Liste de quincaillerie

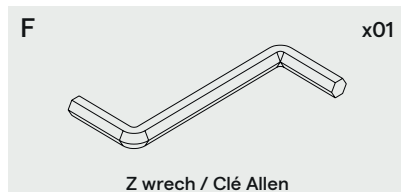
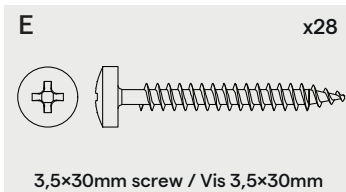
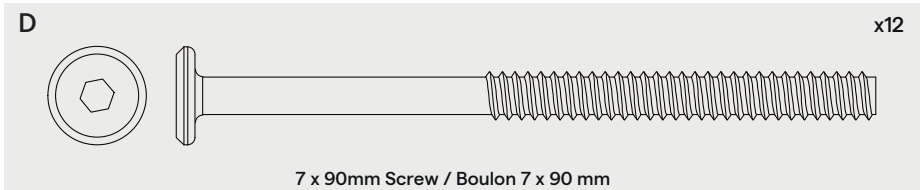
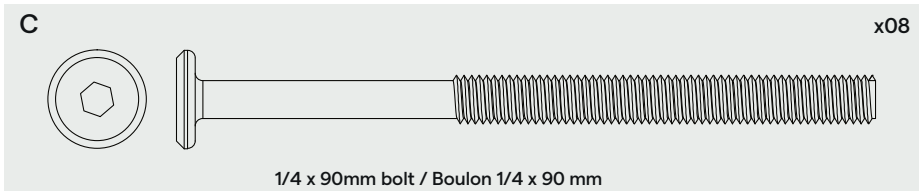
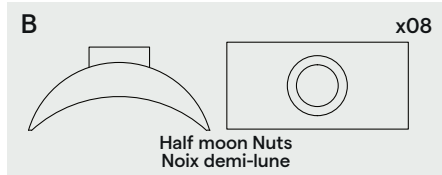
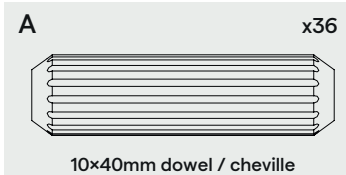

1. 07 08 09

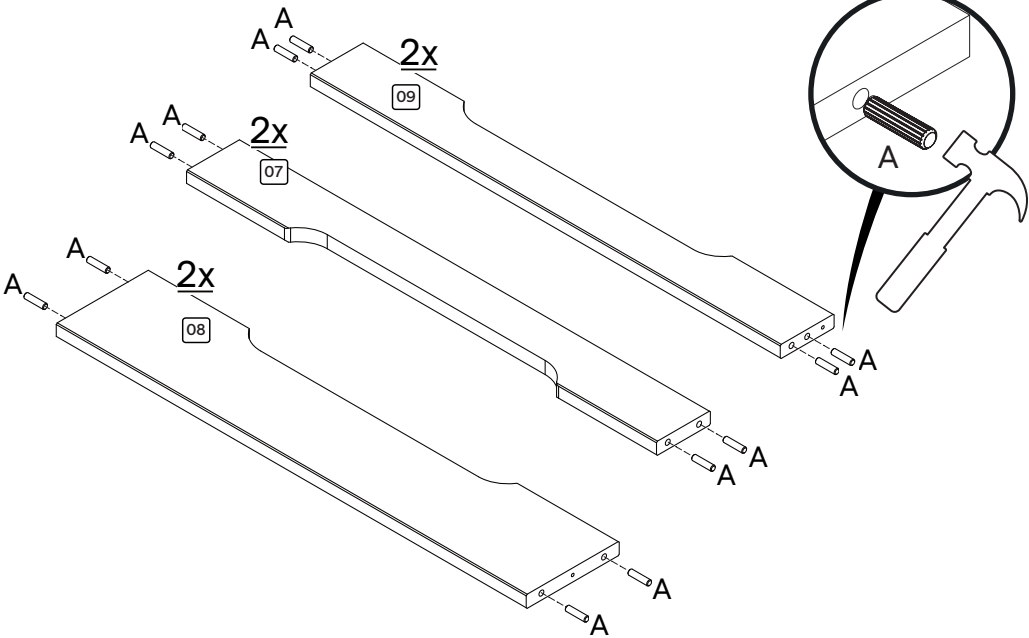
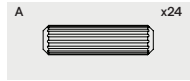

2. 01

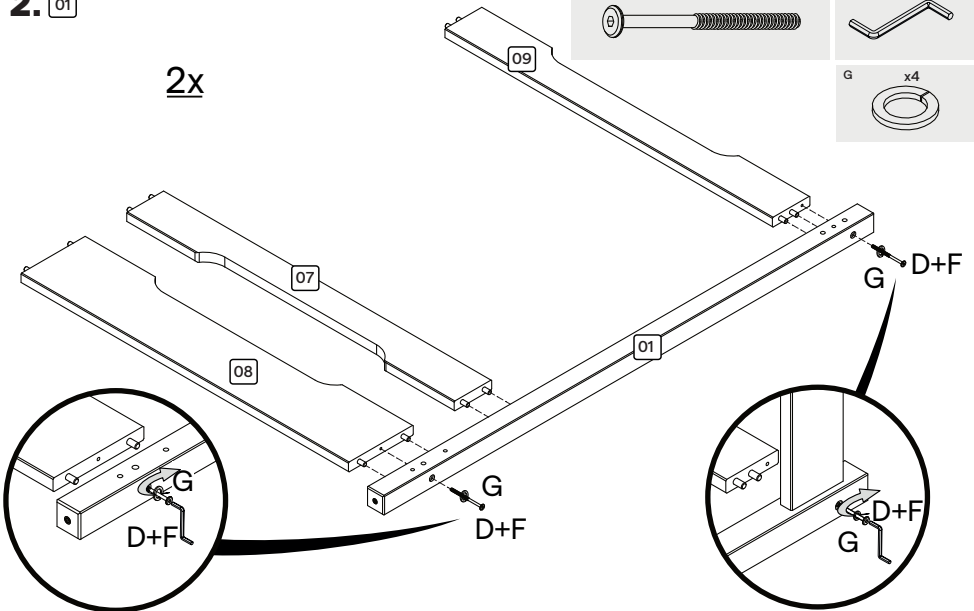
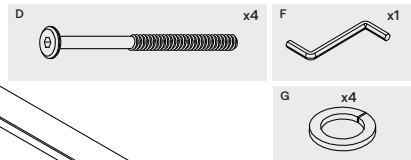

3. 10

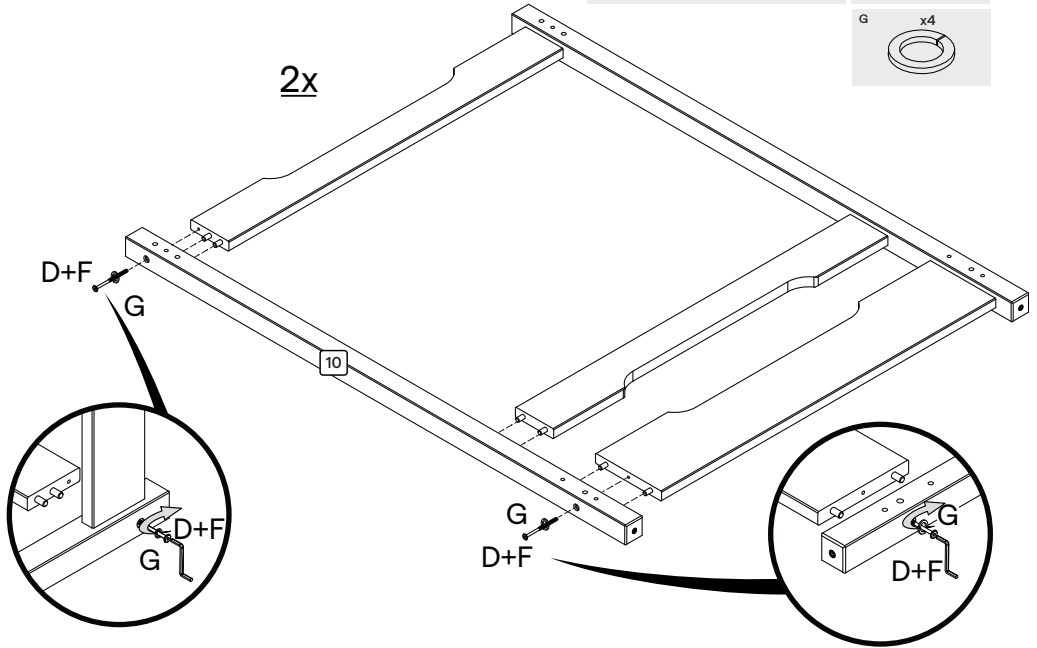
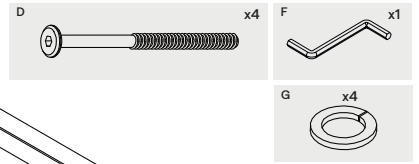

4. 04

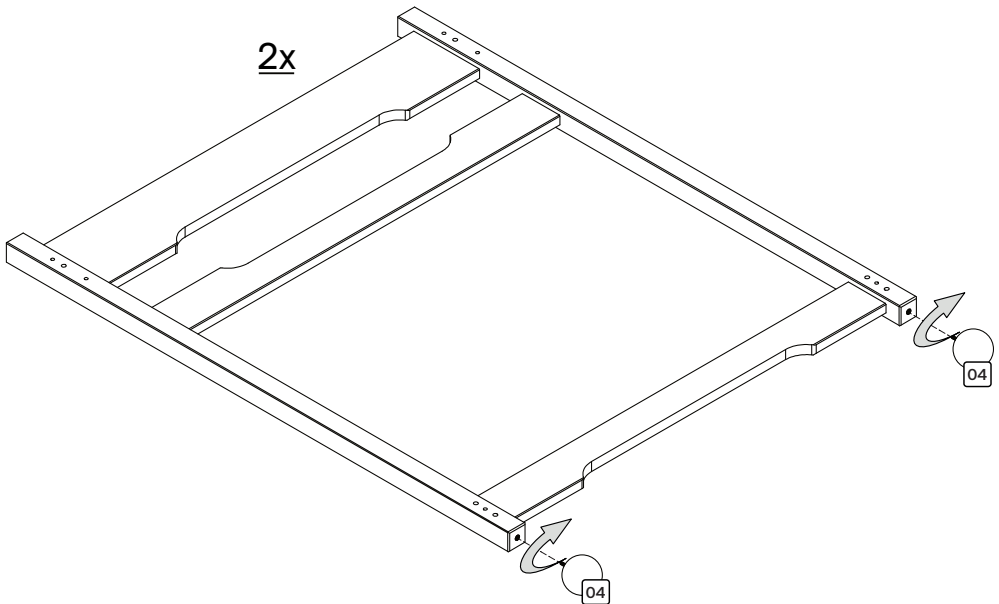

7. 05

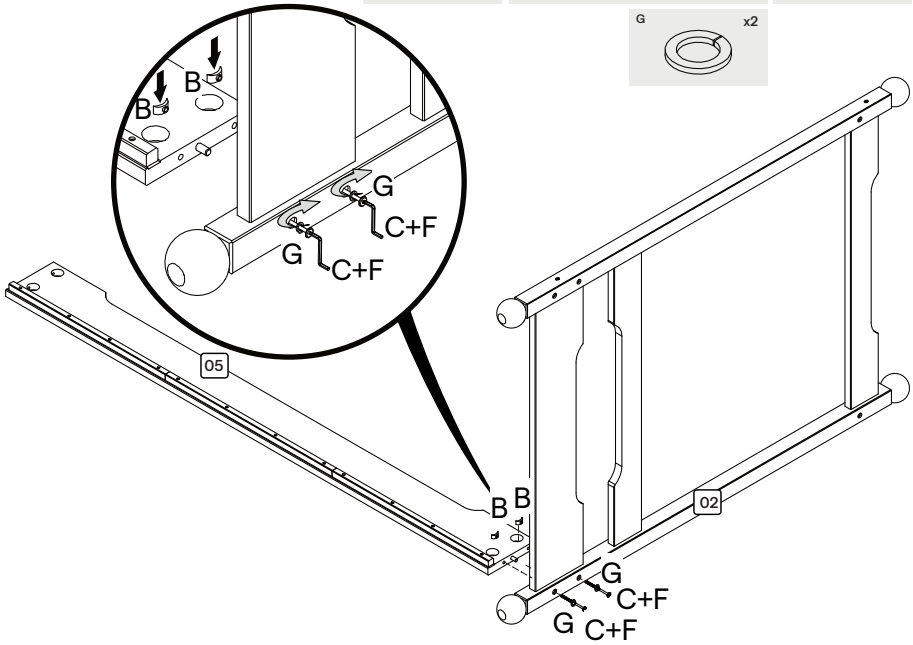
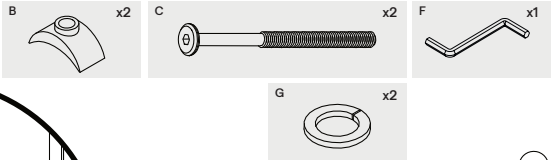

8. 02

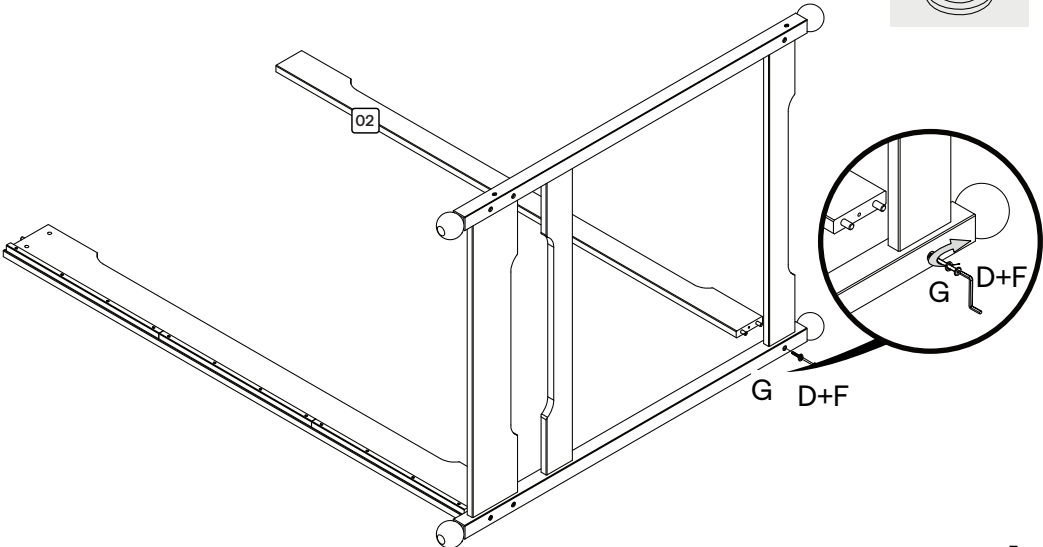
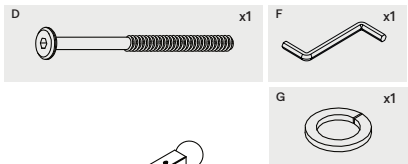

9. 02

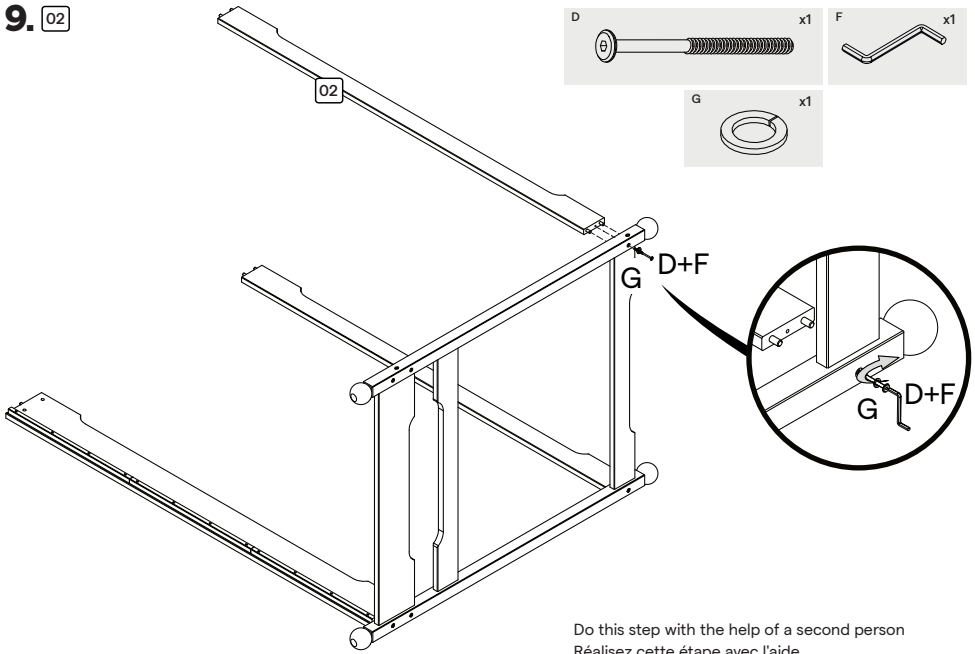

Do this step with the help of a second person
 Réalisez cette étape avec l'aide
 d'une deuxième personne

10. 05

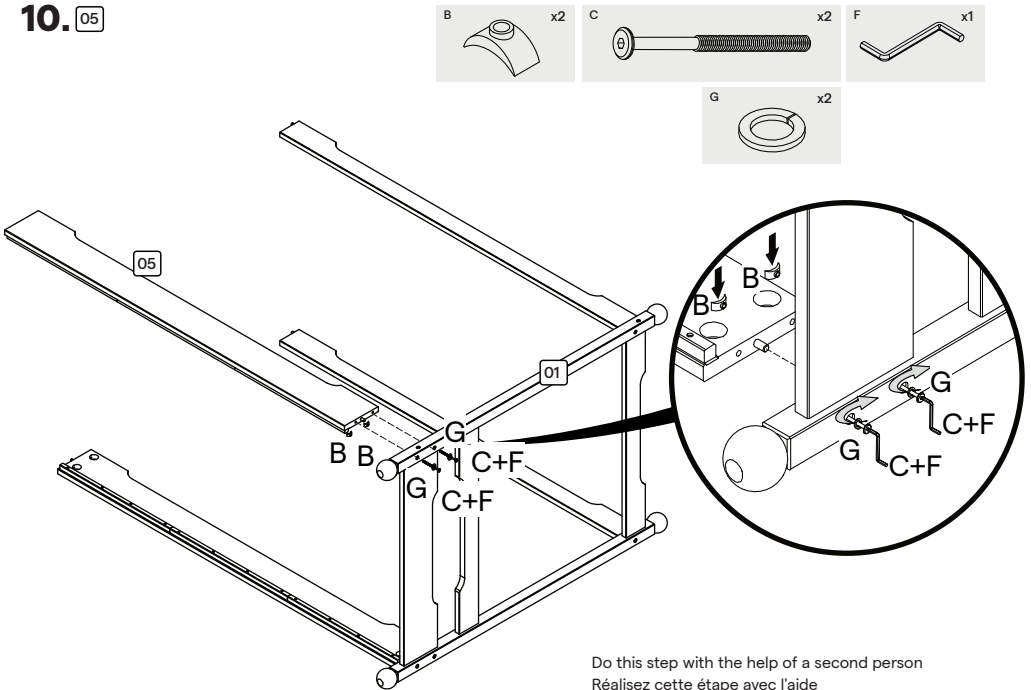

Do this step with the help of a second person
 Réalisez cette étape avec l'aide
 d'une deuxième personne

11.

Do this step with the help of a second person
Réalisez cette étape avec l'aide
d'une deuxième personne

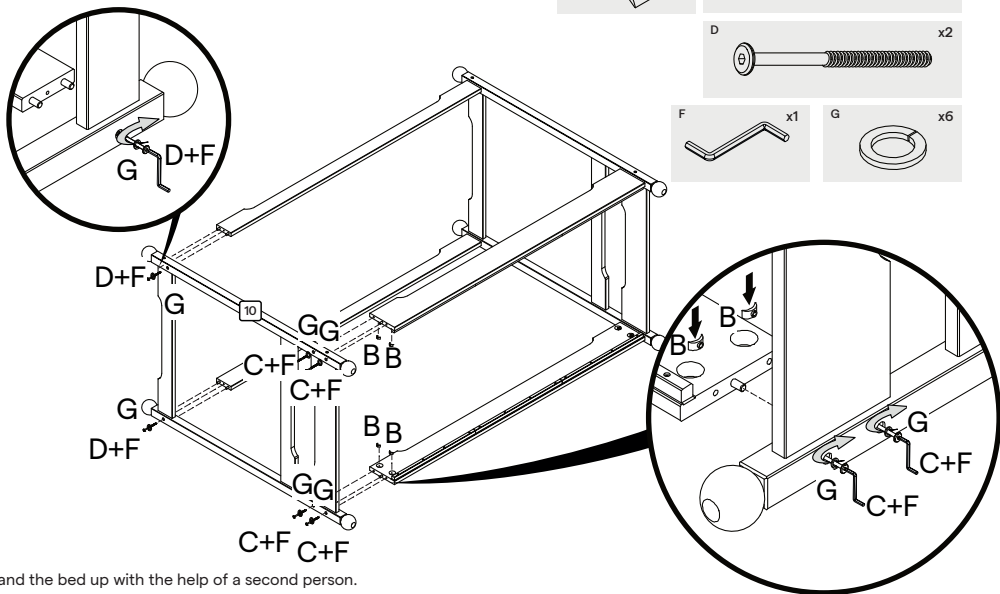
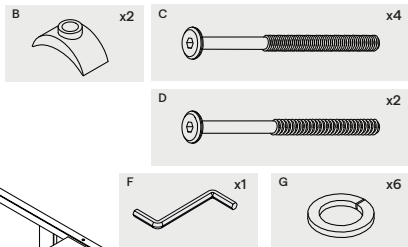

Stand the bed up with the help of a second person.
Avec l'aide d'une autre personne, mettez les meubles debout.

12. 06

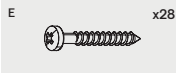
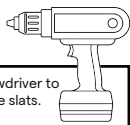

Suggestion: use a electric screwdriver to
thread the screws to attach the slats.
Suggestion: utilisez un tournevis électrique pour
fileter les vis afin de fixer le cadre du lit.

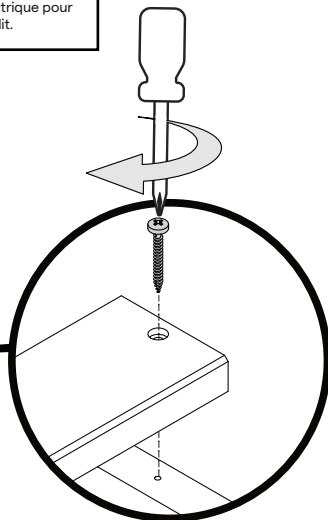
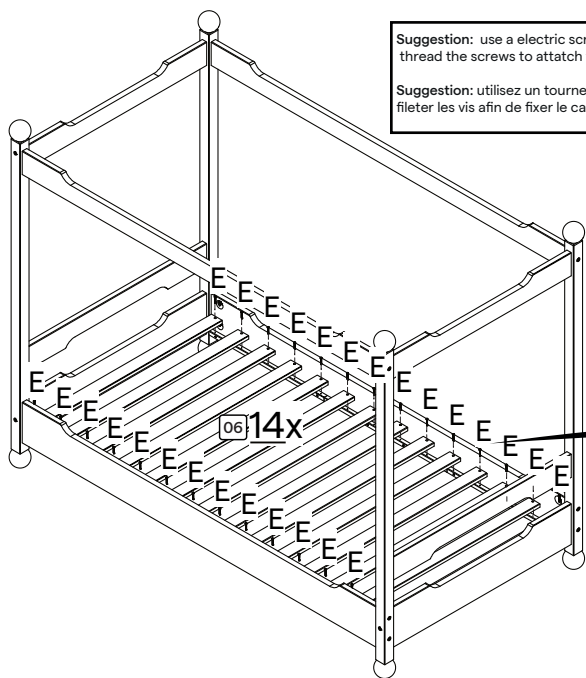

We're Here to Help!

Our product specialists are on hand to answer any questions, help you set up and use your Nestig products, and bring the nursery you imagine to life:

Email us at hello@nestig.com
www.nestig.com/support
Monday - Friday | 10am-5pm ET

Nous sommes là pour vous aider!

Nos spécialistes produits sont à votre disposition pour répondre à toutes vos questions, vous aider à installer et utiliser vos produits Nestig et donner vie à la chambre d'enfant que vous imaginez:

Contactez-nous au hello@nestig.com
www.nestig.com/support
Lundi - Vendredi | 10h-17h HE



nestig.com



Nestig Inc.

hello@nestig.com

PO Box 1106, New York, NY 10023