

NESTiG

The Mountain Crib



Please read all instructions before assembly
and use of product!

Lisez toutes les instructions avant
d'assembler et d'utiliser le produit!

Welcome to the Nestig World!

Our 18 Year Warranty

Our cribs come with a limited 18 year warranty! We do our best to ensure everything arrives in perfect shape but if anything arrives damaged, missing, or defective, our Customer Experience team is here to help.—just email us at hello@nestig.com!

For more information on our warranty, visit:
<https://www.nestig.com/pages/warranty-policy>

Crib Storage

To clean your crib, use a soft cloth with a non-toxic cleaner and wipe dry immediately. To avoid scratches or other damages, do not use abrasive chemicals or materials.

Please store your crib and conversion kits in temperate environments; they should not be near radiators, heaters, humidifiers or air-conditioning vents. Any dramatic changes such as extreme heat, cold, dampness or dryness may cause shrinkage or swelling of the wood. Placing the crib in direct sunlight may affect the color of the materials over time.

Bienvenue dans le monde de Nestig!

Notre garantie de 18 ans

Nos lits bébé sont accompagnés d'une garantie limitée de 18 ans! Nous faisons de notre mieux pour que tout arrive forme parfaite mais si quelque chose arrive endommagé, manquant ou défectueux, notre équipe Expérience Client est heureuse de vous aider. Envoyez-nous un e-mail à hello@nestig.com!

Pour plus d'informations sur notre garantie, visitez
<https://www.nestig.com/pages/warranty-policy>

Entretien et Stockage

Pour nettoyer votre lit bébé, utilisez un chiffon doux avec un nettoyant non toxique et essuyez-le immédiatement. Pour éviter les rayures ou autres dommages, n'utilisez pas de produits chimiques abrasifs ou de matériaux abrasifs.

Veillez ranger votre lit bébé et les kits de conversion dans des environnements tempérés; ils ne doivent pas être près des radiateurs, des chauffages, des humidificateurs ou des bouches de ventilation de climatisation. Tout changement dramatique tel que la chaleur extrême, le froid, l'humidité ou la sécheresse peut provoquer un rétrécissement ou un gonflement du bois. Placer le lit bébé en plein soleil peut affecter a couleur des matériaux avec le temps.

Crib Warnings

WARNING:

Failure to follow these warnings and the assembly instructions could result in serious injury or death.

READ ALL INSTRUCTIONS BEFORE ASSEMBLING CRIB. KEEP THE MANUAL FOR FUTURE USE.

Parents should ensure a safe environment for the child by checking regularly, before placing the child in the product, that every component is properly and securely in place.

- Do not use this crib if you cannot exactly follow the accompanying instructions.
- Infants can suffocate on soft bedding. Never add a pillow or comforter. Never place additional padding under an infant.
- To reduce the risk of SIDS, pediatricians recommend healthy infants be placed on their backs to sleep, unless otherwise advised by your physician.
- Strangulation Hazard: Strings can cause strangulation! Do not place items with a string around a child's neck, such as hood strings or pacifier cords. Do not place cords, straps, or similar items that could become wound around the child's neck in or near this crib. Do not suspend strings over a crib or attach strings to toys.
- To help prevent strangulation tighten all fasteners. A child can trap parts of the body or clothing on loose fasteners.
- DO NOT place a crib near a window where cords from blinds or drapes may strangle a child. Do not place this crib near a window or a patio door where a child could reach the cord of a blind or curtain and be strangled.
- Fall Hazard: When a child is able to pull to a standing position, set the mattress to the lowest position and remove bumper pads, large toys and other objects that could serve as steps for climbing out.
- Do not use this crib if the child is able to climb out unaided or is taller than 35 in. (89cm).

Crib Warnings

WARNING:

Failure to follow these warnings and the assembly instructions could result in serious injury or death.

- Check this product for damaged hardware, loose joints, loose bolts or other fasteners, missing parts or sharp edges before and after assembly and frequently during use. Securely tighten loose bolts and other fasteners. DO NOT use crib if any parts are missing, damaged or broken. DO NOT substitute parts. Contact **Nestig** for replacement parts and instructional literature if needed.
- If refinishing, use a non-toxic finish specified for children's products.
- Never use plastic shipping bags or other plastic films as mattress covers because they can cause suffocation.
- Infants can suffocate in gaps between crib sides when used with a mattress that is too small.
- Follow warnings on all products in a crib.

**CAUTION: ANY MATTRESS
USED IN THIS CRIB MUST BE AT
LEAST 27 1/4 INCHES (69CM)
BY 51 5/8 INCHES (131CM)
WITH A THICKNESS NOT
EXCEEDING 6 INCHES (15CM).**

Toddler-Bed Warnings

WARNING:

INFANTS HAVE DIED IN TODDLER BEDS FROM ENTRAPMENT.

Openings in and between bed parts can entrap head and neck of a small child. NEVER use bed with children younger than 15 months. ALWAYS follow assembly instructions.

WARNING:

STRANGULATION HAZARD

NEVER place bed near windows where cords from blinds or drapes may strangle a child.

NEVER suspend strings over bed.

NEVER place items with a string, cord, or ribbon, such as hood strings or pacifier cords, around a child's neck. These items may catch on bed parts.

CAUTION:

ENTRAPMENT HAZARD

To avoid dangerous gaps, any mattress used in this bed shall be a full-size crib mattress at least 51 5/8 in. (1310 mm) in length, 27 1/4 in. (690 mm) in width., and a max thickness of 6 in. (150 mm).

**THE INTENDED USER'S
MINIMUM AGE MUST BE AT
LEAST 15 MONTHS OLD AND
MAXIMUM WEIGHT MUST
NOT EXCEED 50 LBS (22.7 KG).**

NESTiG

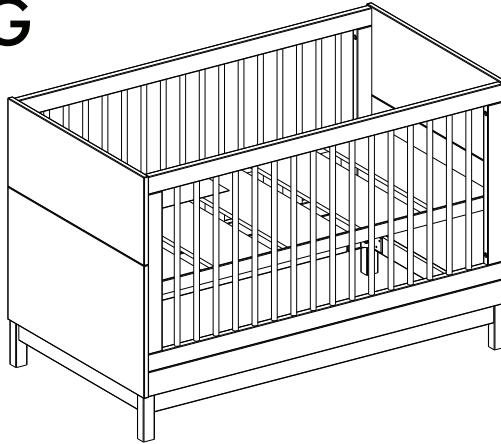

Use the ruler below to measure the hardware

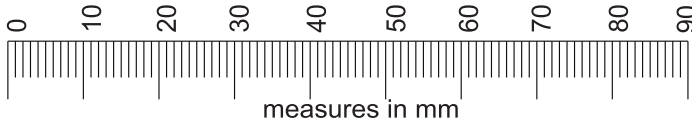





#	Product Part	Qty.
1	Lower Headboard	01
2	Lower Footboard	01
3	Mattress Support	01
4	Side Panel	02
5	Rails	02
6	Left Foot	02
7	Right Foot	02
8	Upper Headboard	01
9	Upper Footboard	01
10	Assembled Base	01



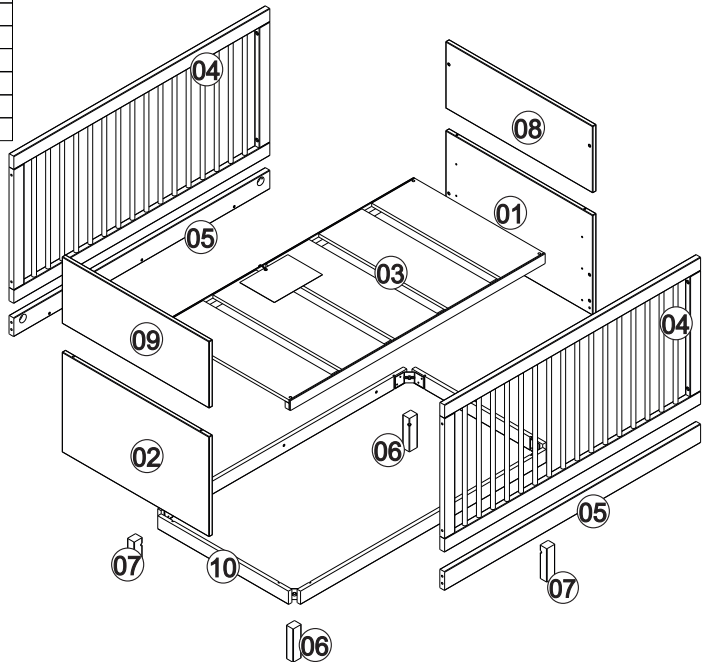

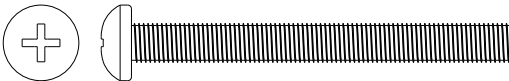
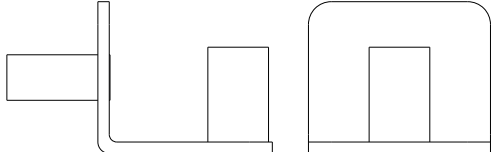
Crib Assembly
Steps 01 - 12

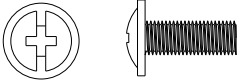
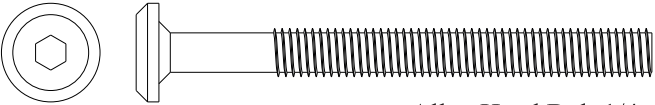
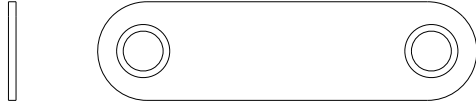
Mattress Support
Height Adjustment
Steps 13 - 15

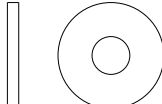
Toddler Bed Assembly
Steps 16 - 20

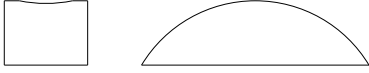
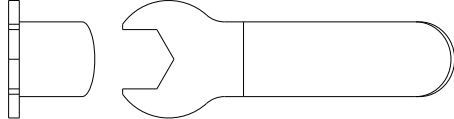
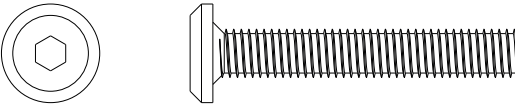

A	 <p>Phillips Head Bolt M5x50</p>	Qty: 04
B	 <p>Mattress Support Bolt M5</p>	04
C	 <p>Allen Wrench</p>	01
D	 <p>Phillips Head Bolt M4x12</p>	12
E	 <p>Allen Head Bolt 1/4x65</p>	08
F	 <p>Bracket Connector</p>	06
G	 <p>Lock Washer M5</p>	16
H	 <p>Washer 3/16</p>	04

I		Threaded Rod 1/4x60 Qty: 04
J		Half Moon Nut 04
K		Wrench 01
L		Allen Head Bolt 1/4x40 04
M		Dowel 8x30 04
N		Hexagonal Nut 04
O		Lock Washer 1/4 16
P		Dowel 8x50 04

01 →

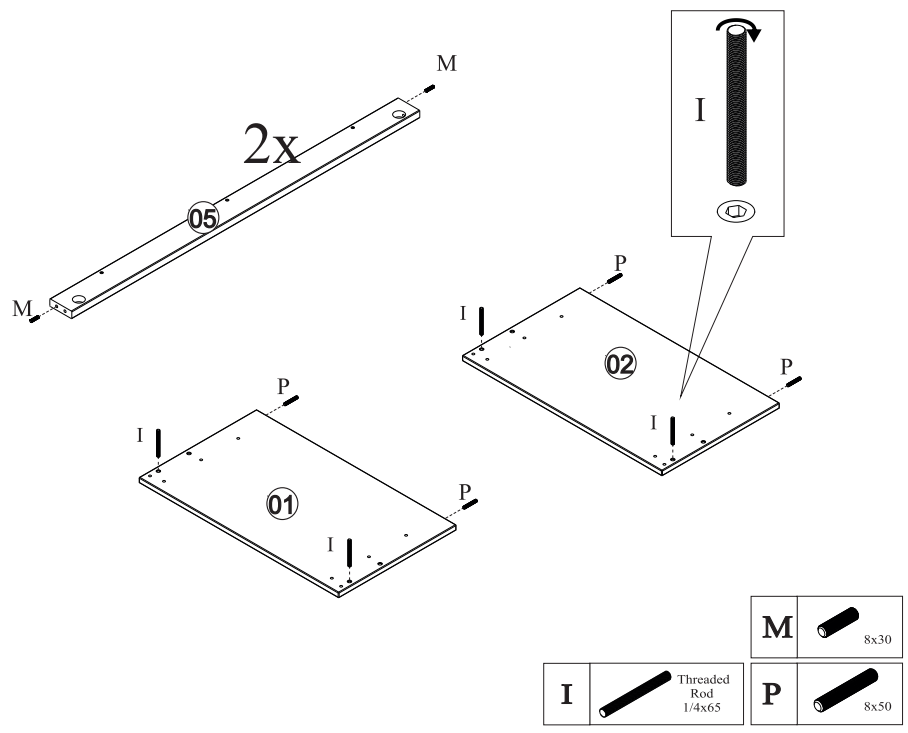

02 →

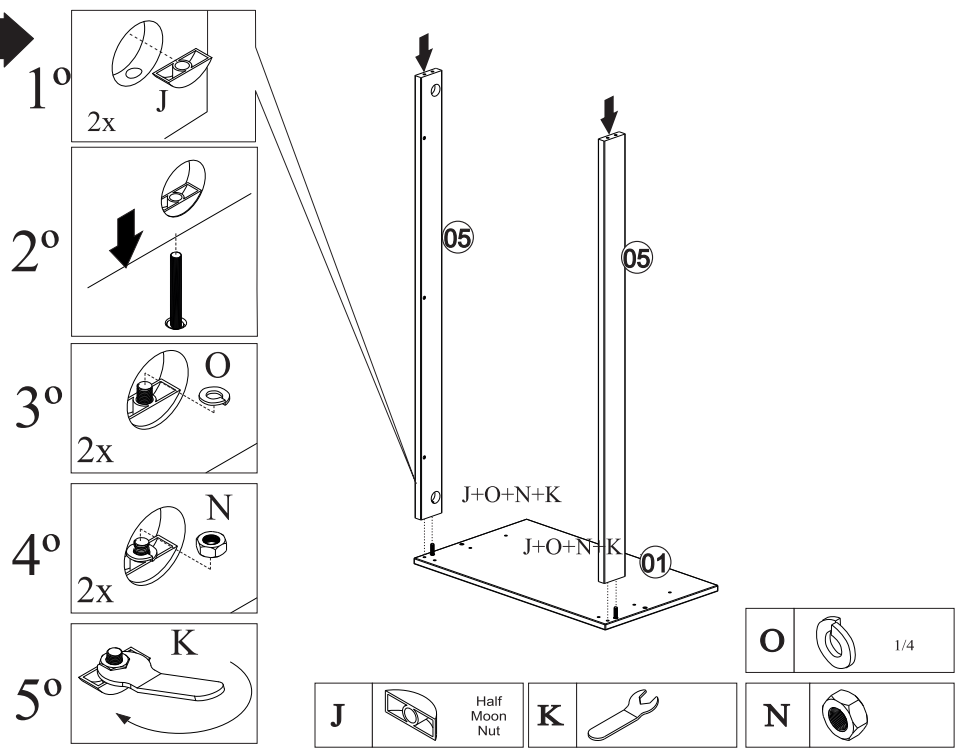

03

1°

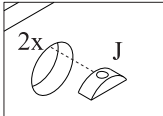

2°

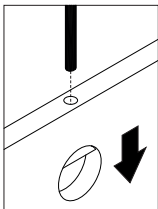

3°

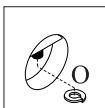

4°

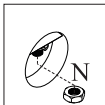

5°

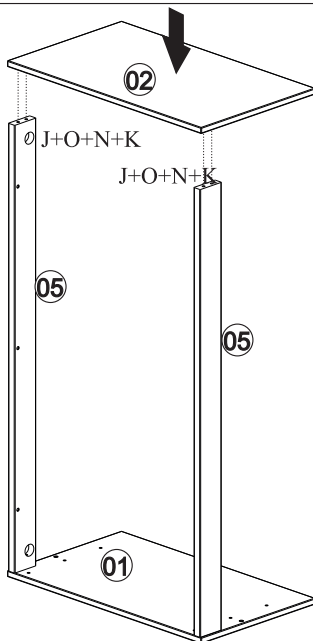
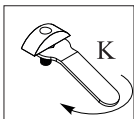
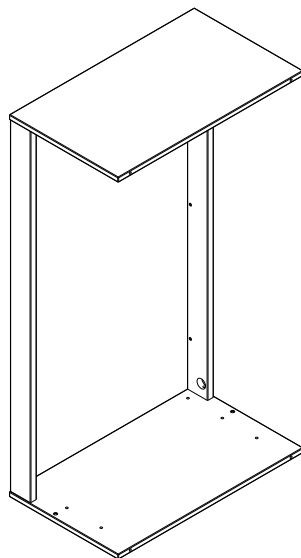
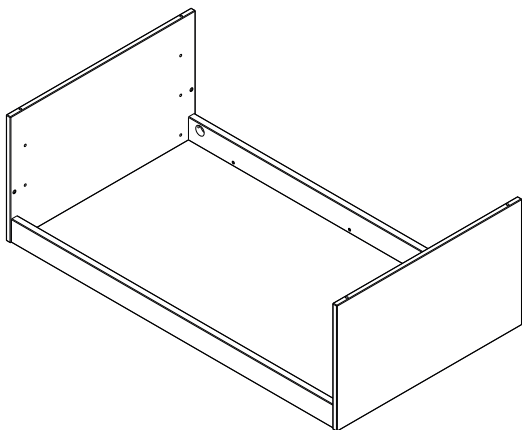
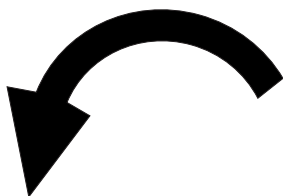
**04**

05 →

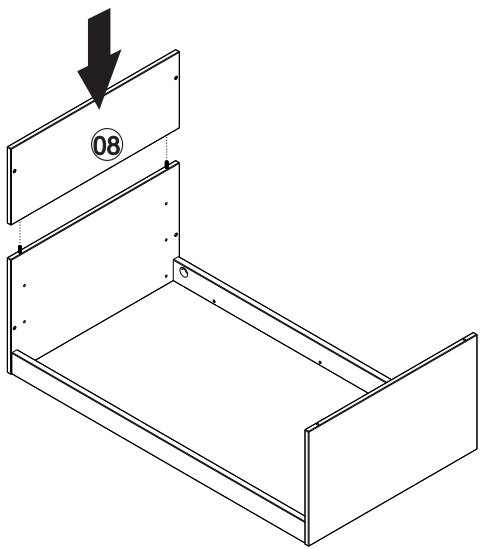

06 →

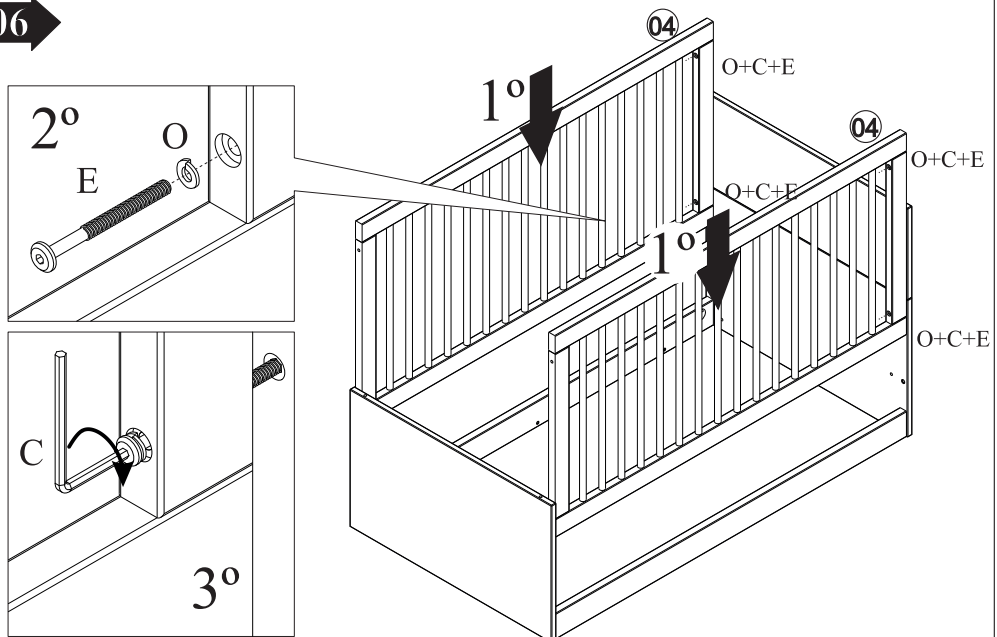

07

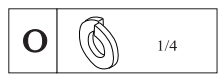
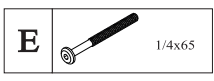
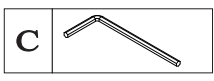
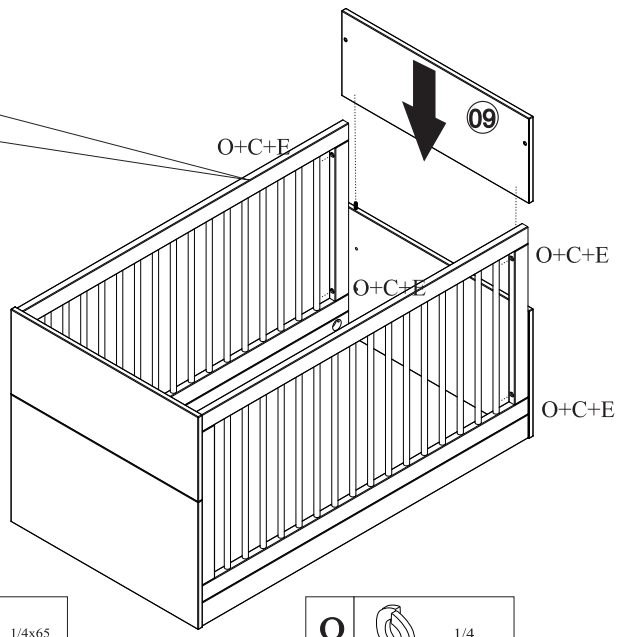
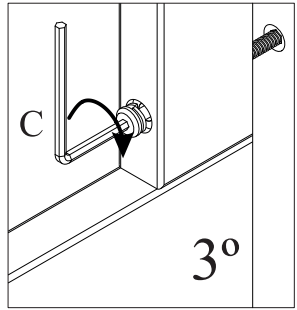
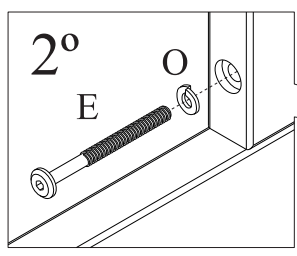

08

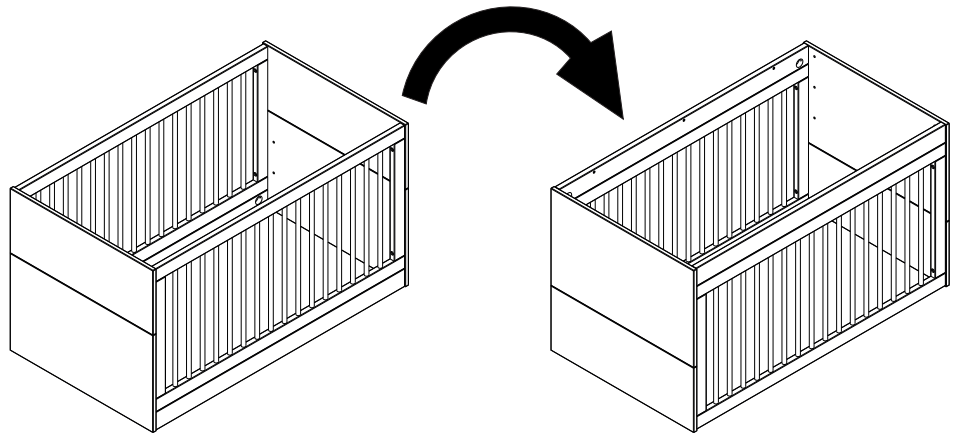

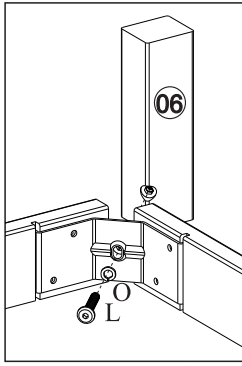

09 →

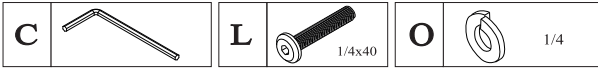
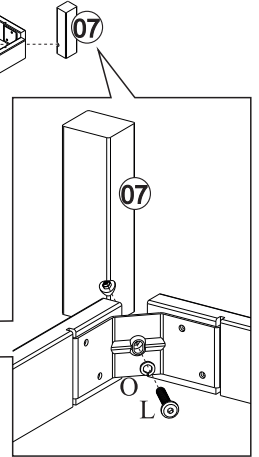
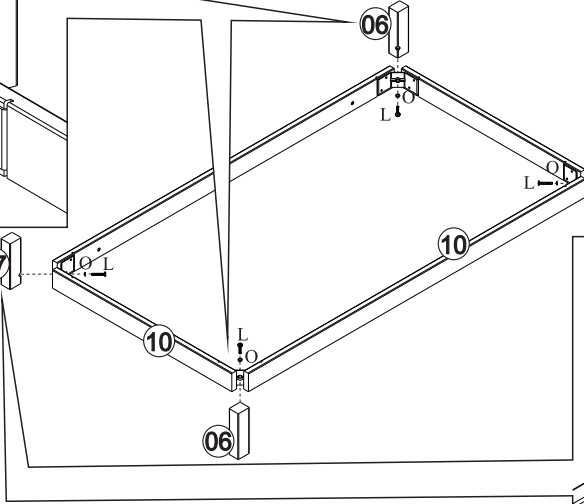

10 →

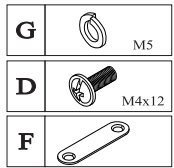
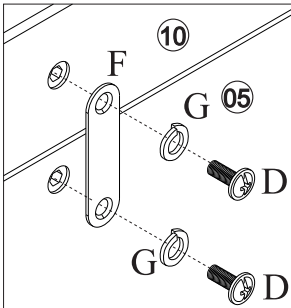
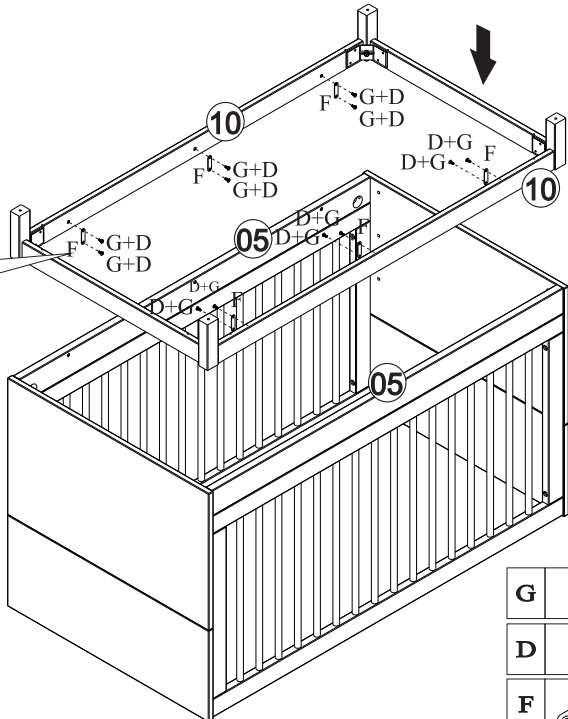

11

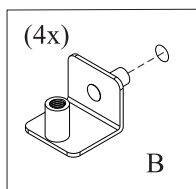
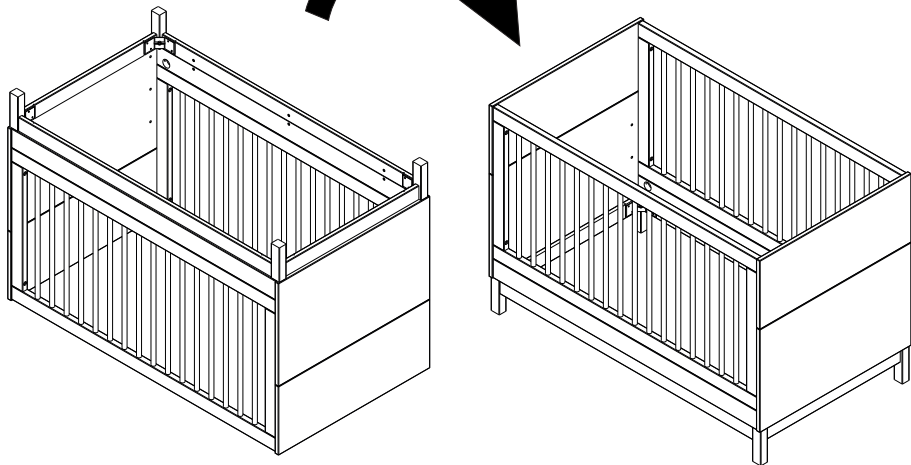

1°

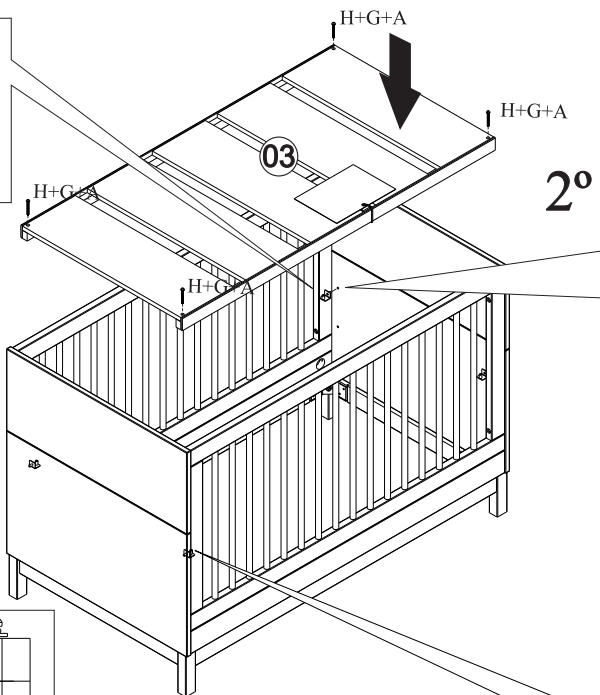

2°

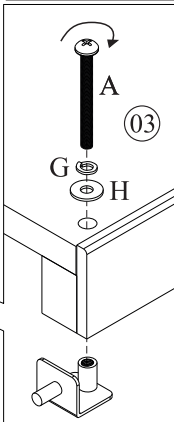
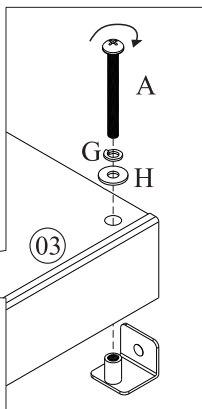

3°

12

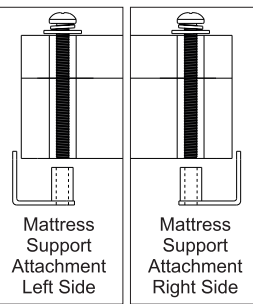

Mattress Support Attachment Left Side

Mattress Support Attachment Right Side

- | | | | |
|---|---|--|---|
| A  M5x50 | B  | G  M5 | H  3/16 |
|---|---|--|---|

Mattress Support Height Adjustment

1° - Remove Screw (A)

2° - Remove Mattress Support (03)

13

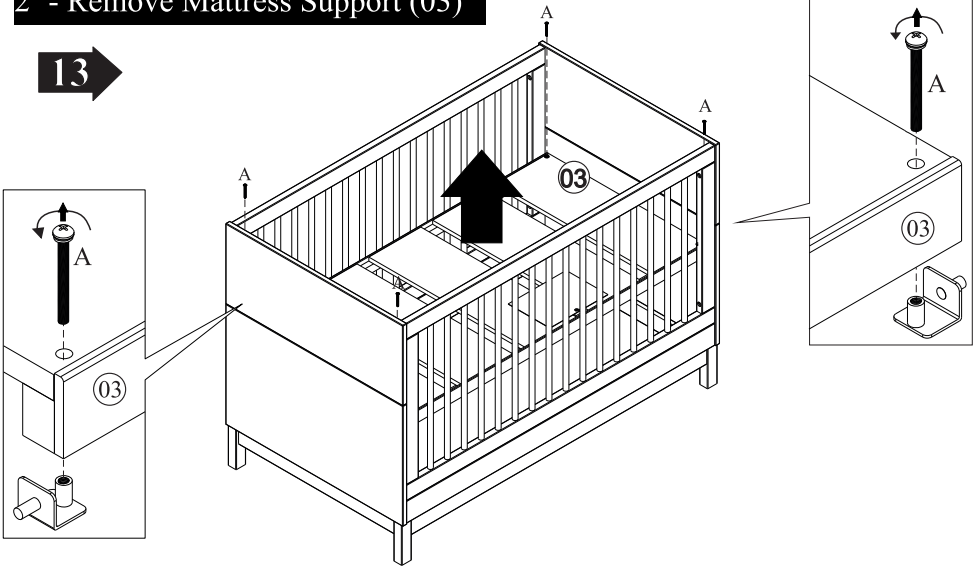

14

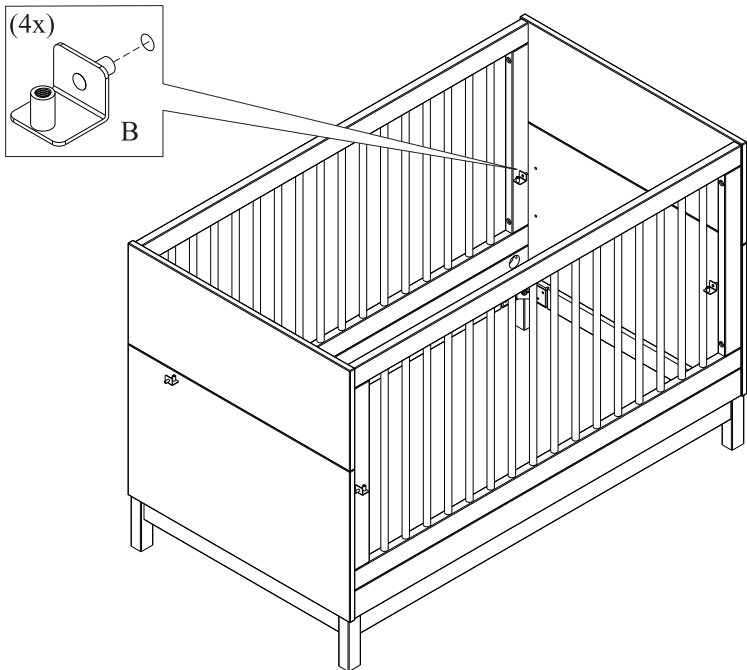

Place Mattress Support (B) on the desired height and follow the instructions below:

15

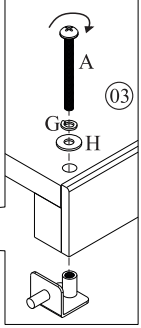
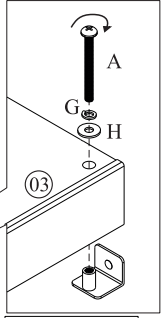
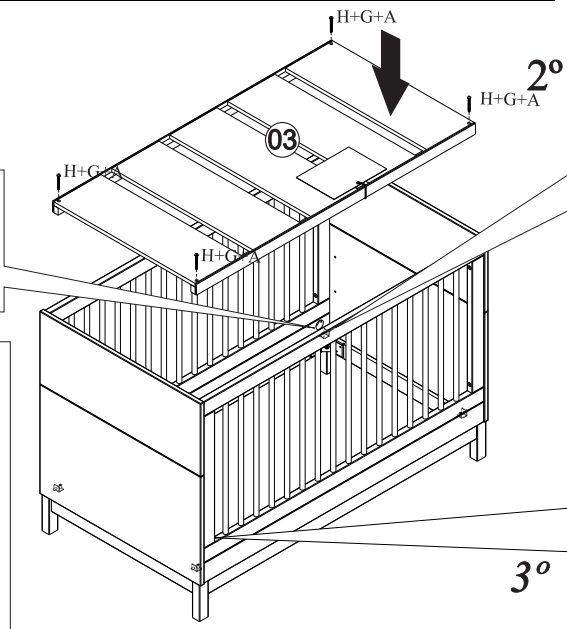
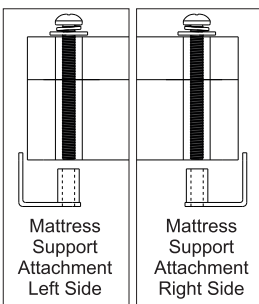
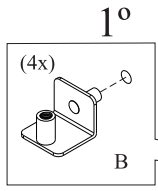

Toddler-Bed Assembly Instructions:

16

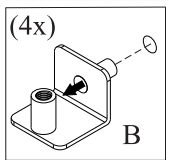
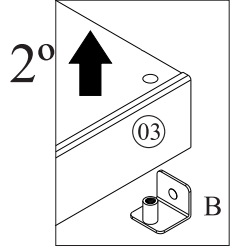
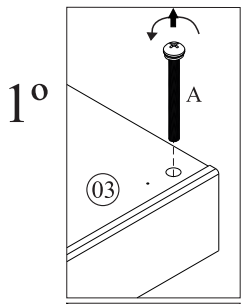
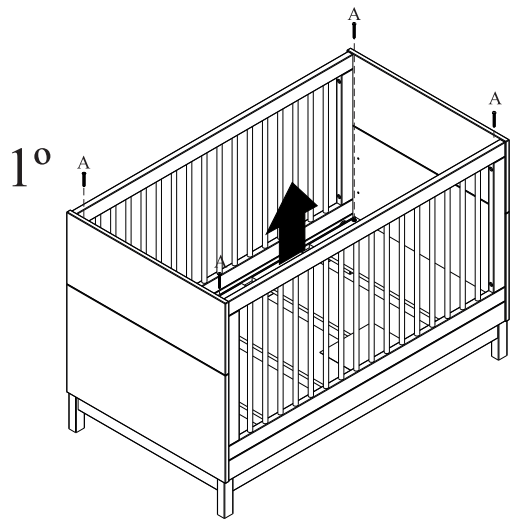
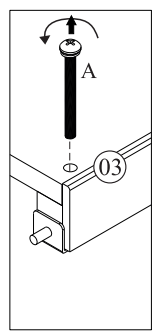

1° - Remove Screw (A)
2° - Remove Mattress Support (03)

3°

18

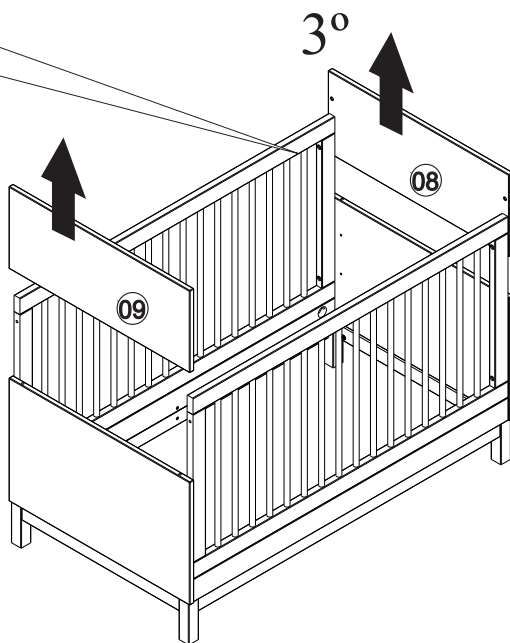
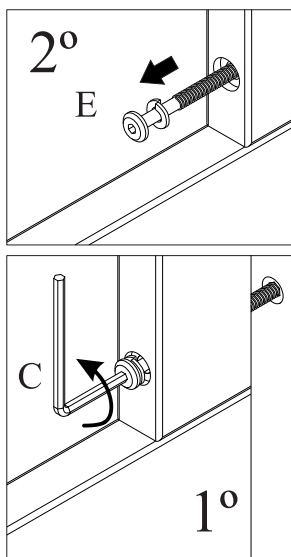

1° - Remove Screw (E)
2° - Remove Panels (08+09)

19

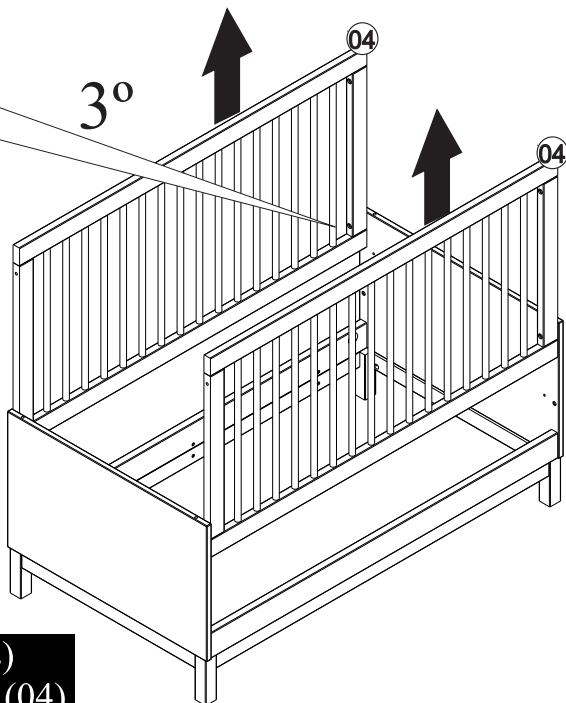
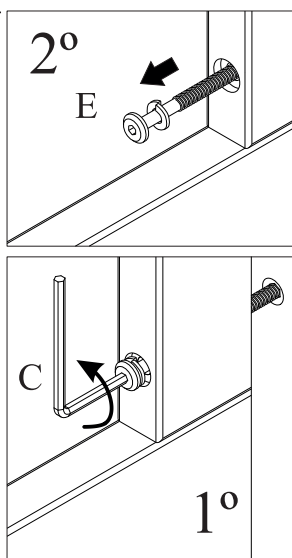

1° - Remove Screw (E)
2° - Remove Side Panels (04)

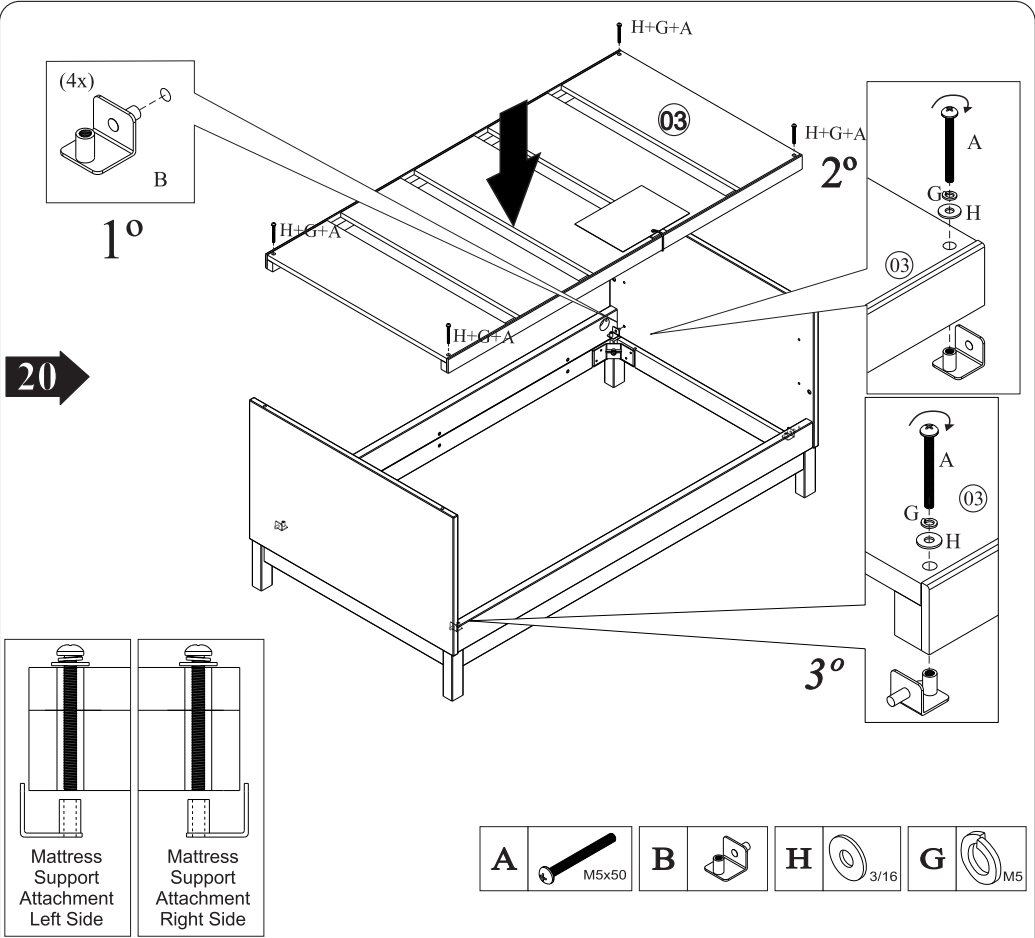

20

We're Here to Help!

Our product specialists are on hand to answer any questions, help you set up and use your Nestig products, and bring the nursery you imagine to life:

Email us at hello@nestig.com
www.nestig.com/support
Monday - Friday | 10am-5pm ET

Nous sommes là pour vous aider!

Nos spécialistes produits sont à votre disposition pour répondre à toutes vos questions, vous aider à installer et utiliser vos produits Nestig et donner vie à la chambre d'enfant que vous imaginez:

Contactez-nous au hello@nestig.com
www.nestig.com/support
Lundi - Vendredi | 10h-17h HE



nestig.com



Nestig, Inc.
hello@nestig.com
PO Box 1106, New York, NY 10023