

NESTiG

The Wave Kids Bed



Please read all instructions before assembly
and use of product!

Lisez toutes les instructions avant
d'assembler et d'utiliser le produit!

Welcome to the Nestig World!

Our Warranty

Our twin beds come with a limited 2 year warranty! We do our best to ensure everything arrives in perfect shape but if anything arrives damaged, missing, or defective, our Customer Experience team is here to help.—just email us at hello@nestig.com!

For more information on our warranty, visit:
<https://www.nestig.com/pages/warranty-policy>

Bed Care & Tips

- To clean your bed, use a soft cloth with a non-toxic cleaner and wipe dry immediately.
- To avoid scratches or other damages, do not use abrasive chemicals or materials.
- Any dramatic changes such as extreme heat, cold, dampness or dryness may cause shrinkage or swelling of the wood.
- Placing the bed in direct sunlight may affect the color of the materials over time.
- Tighten all screws periodically.
- Do not drag the bed - when moving, always use two people to lift it.

Bienvenue dans le monde de Nestig!

Notre garantie

Nos lits jumeaux sont assortis d'une garantie limitée de 2 ans! Nous faisons de notre mieux pour que tout arrive forme parfaite mais si quelque chose arrive endommagé, manquant ou défectueux, notre équipe Expérience Client est heureuse de vous aider. Envoyez-nous un e-mail à hello@nestig.com!

Pour plus d'informations sur notre garantie, visitez:
<https://www.nestig.com/pages/warranty-policy>

Entretien et conseils pour les lits

- Pour nettoyer votre lit, utilisez un chiffon doux avec un nettoyeur non toxique et essuyez immédiatement.
- Pour éviter les rayures ou autres dommages, n'utilisez pas de produits chimiques ou de matériaux abrasifs.
- Tout changement dramatique tel qu'une chaleur extrême, le froid, l'humidité ou la sécheresse peut provoquer le rétrécissement ou le gonflement du bois.
- Placer le lit en plein soleil peut affecter la couleur des matériaux au fil du temps.
- Serrez toutes les vis périodiquement.
- Ne pas le traîner ni le pousser au sol - si vous déplacez le lit, deux personnes doivent le soulever.

Use the ruler below to measure the hardware / Utilisez la règle ci-dessous pour mesurer le matériel

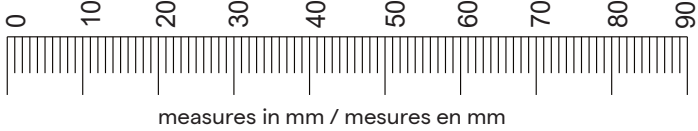

Installation Info / Info sur l'installation

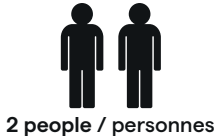

Not Included / Non Inclus	
	Philips head screwdriver Tournevis à tête Philips
	Electric screwdriver Tournevis électrique

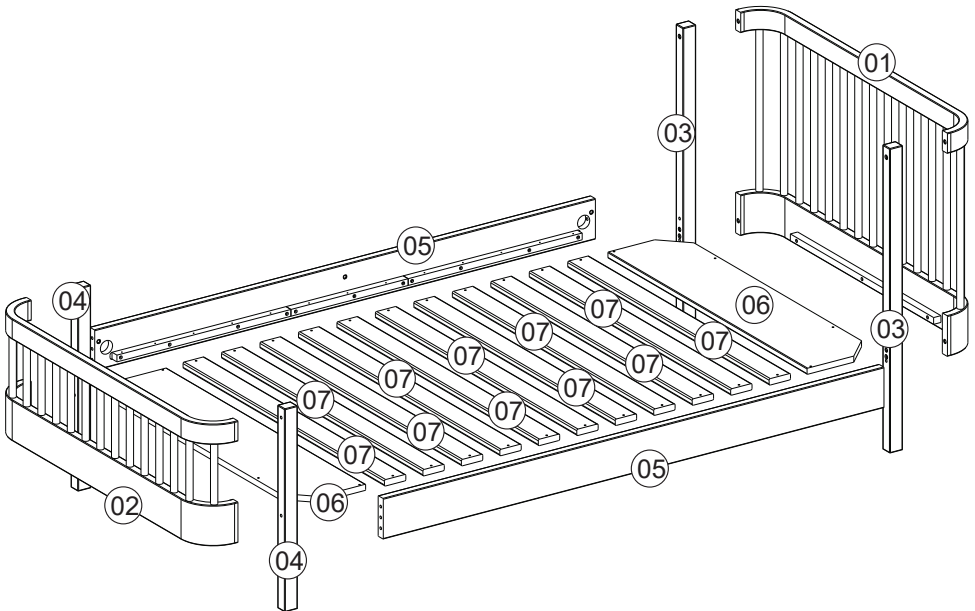

Item / Pièce	Description / description	Quantity / Quantité
01	Headboard / Tête de lit	01
02	Footboard / Marche pied de lit	01
03	Headboard Leg / Jambe de tête de lit	02
04	Footboard Leg / Jambe de marche pied de lit	02
05	Side Rails / Barre de lit	02
06	End Support / Sommier de support de matelas	02
07	Slat / Lattes de sommier	11

Hardware list / Liste de quincaillerie

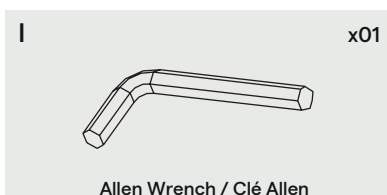
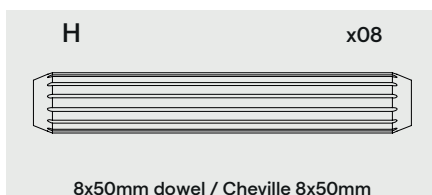
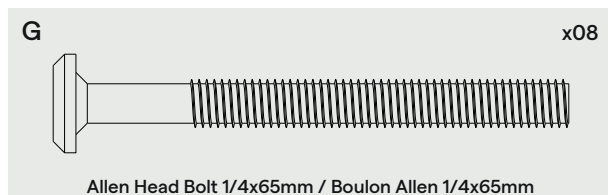
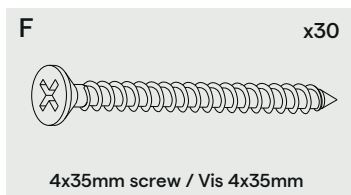
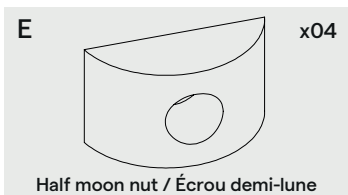
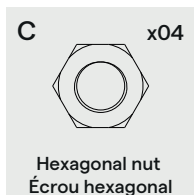
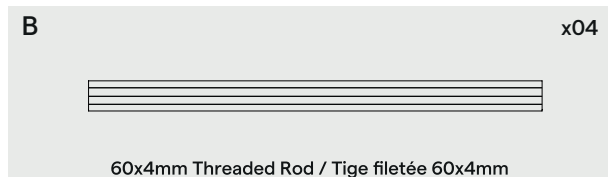
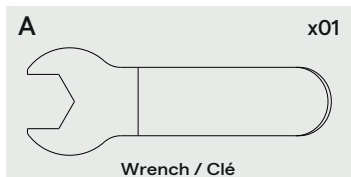

1. 01 03

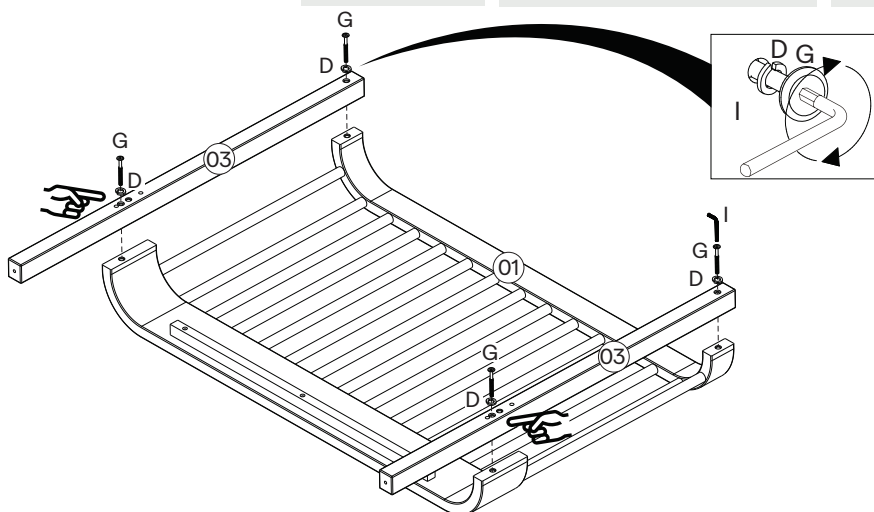
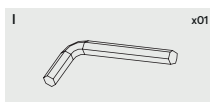

2. 02 04

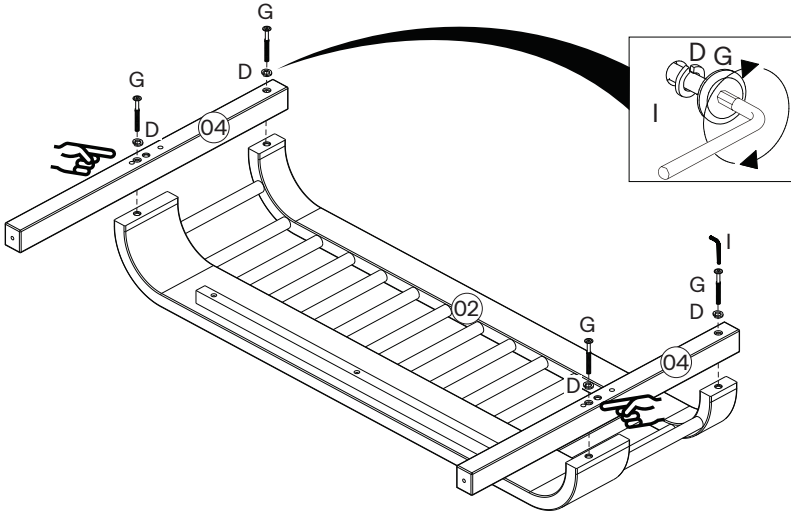
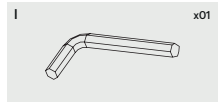
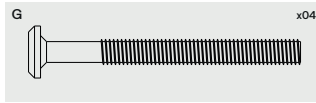

3. 01 02 03 04

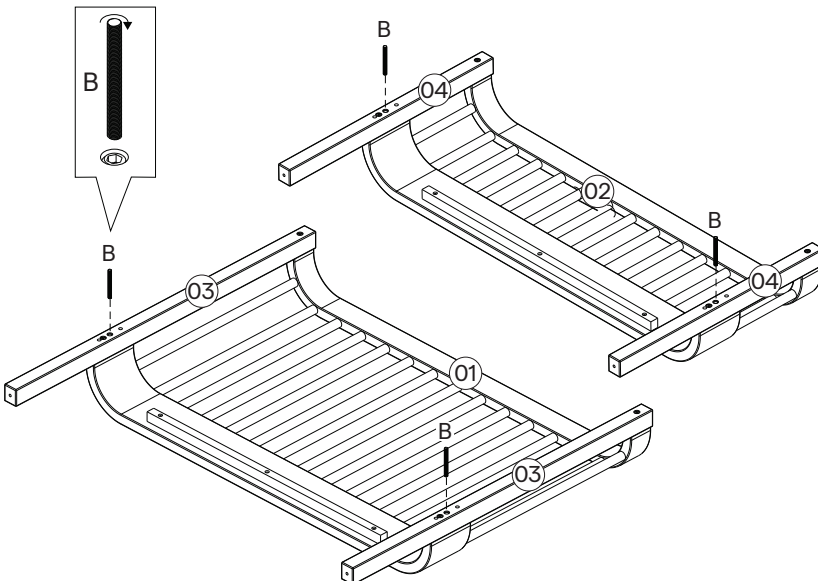

4. 05

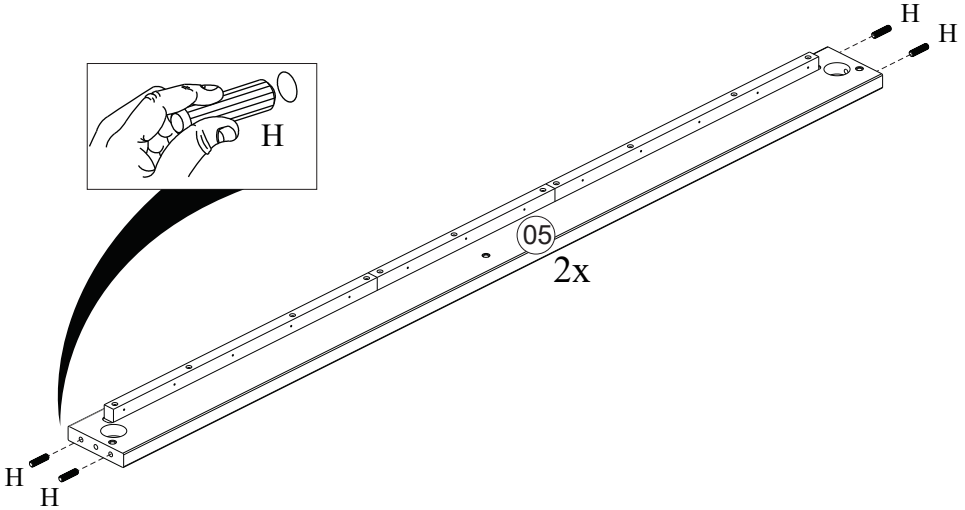
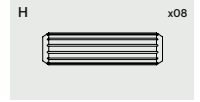

5. 03 04 05

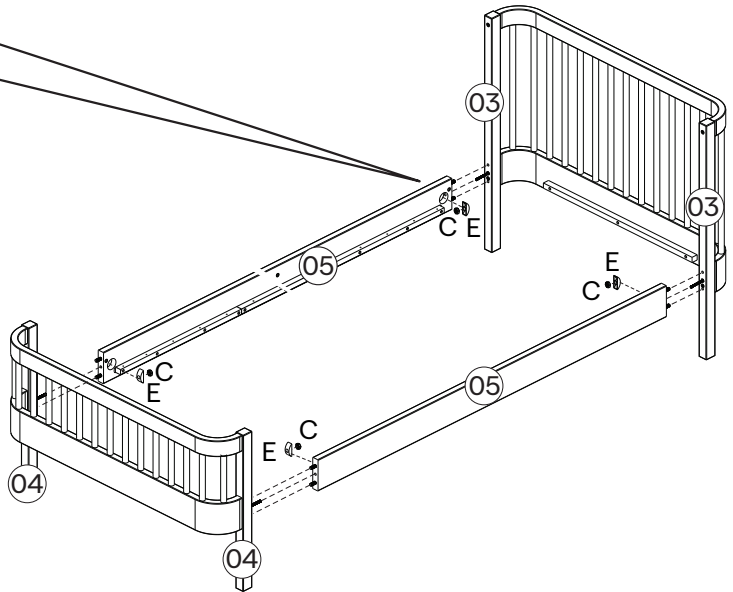
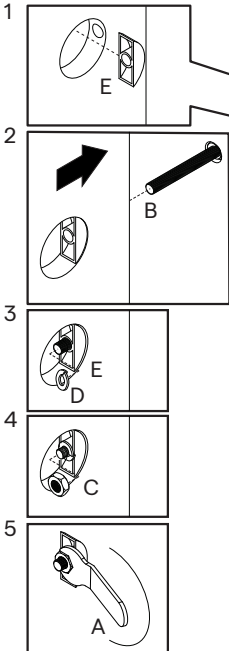

6. 01 02 05 06

First, attach part "06" to both parts "05", to align piece "06" to part "01". After, attach part "06" to part "01"

Tout d'abord, attachez la pièce "06" aux deux pièces "05", pour aligner la pièce "06" sur la pièce "01". Ensuite, attachez la pièce "06" à la pièce "01"

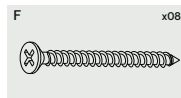
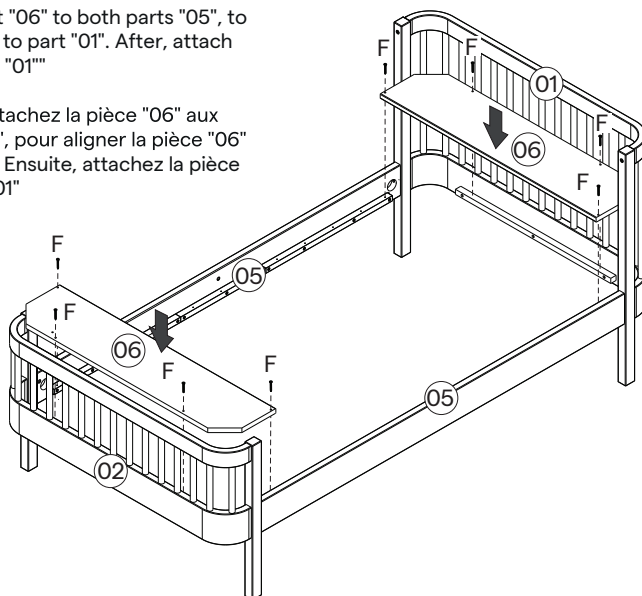

7. 05 07

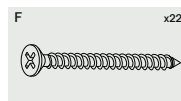
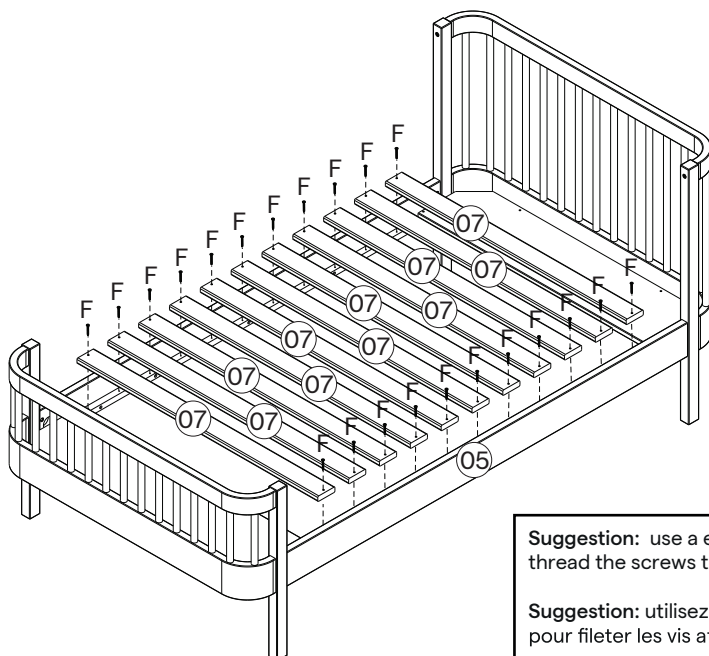

Suggestion: use a electric screwdriver to thread the screws to attach the slats.

Suggestion: utilisez un tournevis électrique pour fileter les vis afin de fixer le cadre de lit.

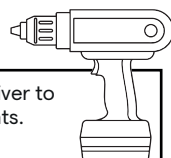

We're Here to Help!

Our product specialists are on hand to answer any questions, help you set up and use your Nestig products, and bring the nursery you imagine to life:

Email us at hello@nestig.com
www.nestig.com/support
Monday - Friday | 10am-5pm ET

Nous sommes là pour vous aider!

Nos spécialistes produits sont à votre disposition pour répondre à toutes vos questions, vous aider à installer et utiliser vos produits Nestig et donner vie à la chambre d'enfant que vous imaginez:

Contactez-nous au hello@nestig.com
www.nestig.com/support
Lundi - Vendredi | 10h-17h HE

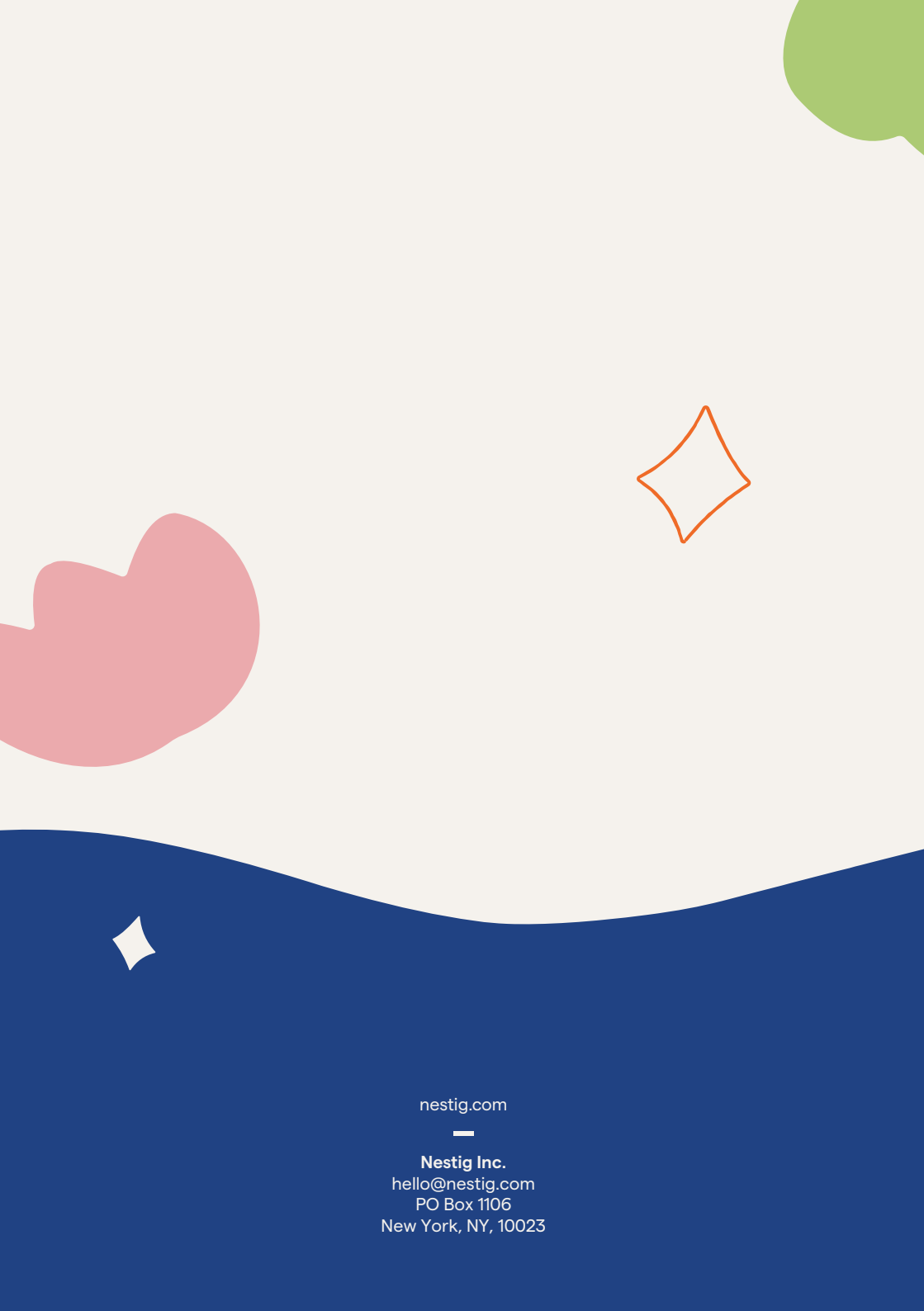

nestig.com



Nestig Inc.
hello@nestig.com
PO Box 1106
New York, NY, 10023